

INSTALLATION INSTRUCTIONS

BAY MASTER M1 CENTER POST



APPLICABLE TO BAY MASTER M1 CENTER POST:
M1 CLASSIC, M1 FIBER FLEX, & M1 MARTIME HARDWOOD
TO PROTECT YOUR PRODUCT, PLEASE READ THE OPERATING INSTRUCTIONS BEFORE OPENING THE PARASOL.
STEPS 2 & 3 WILL CONTINUE TO BE IMPORTANT FOR THE LIFE OF THE UMBRELLA, FOR MORE INFORMATION PLEASE VISIT TUUCI.COM
CLOSE UMBRELLA WHEN NOT IN USE PARTICULARLY IN ADVERSE WEATHER CONDITIONS AND DURING WIND.

BAY MASTER M1 CENTER POST

STEP 1

REMOVE ALL PACKAGING FROM IN AND AROUND PARASOL.

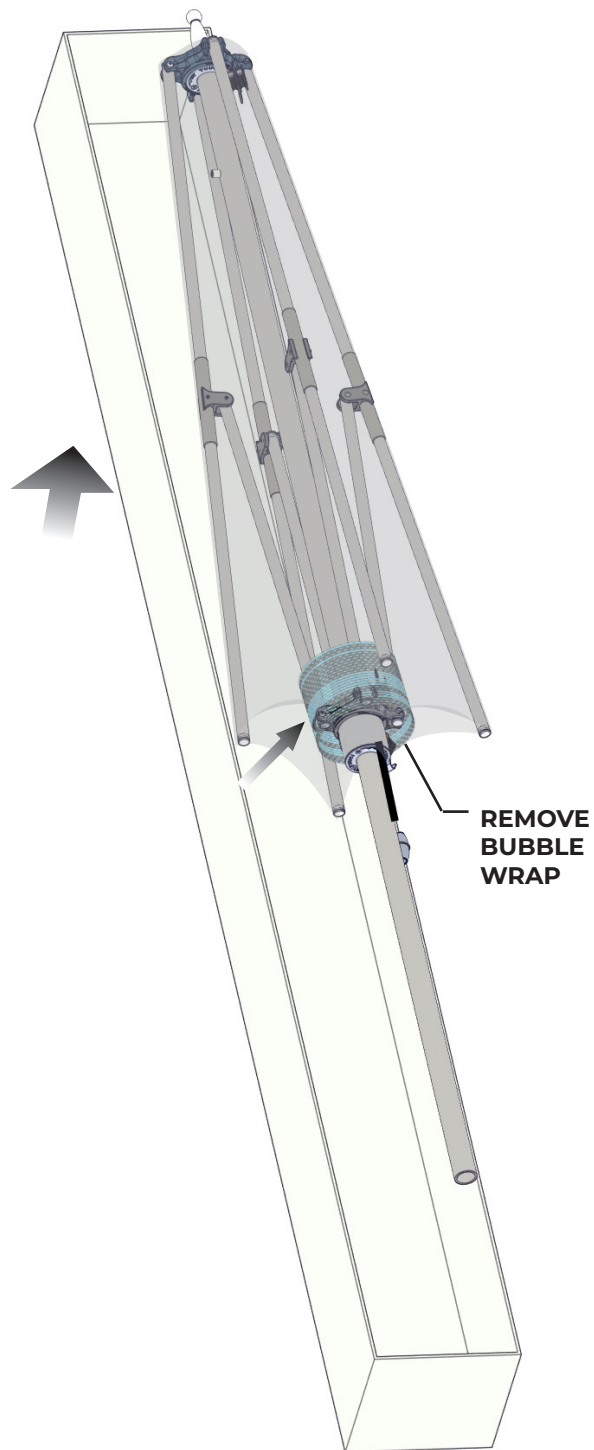

BAY MASTER M1 CENTER POST

STEP 2

INSERT AND SECURE PARASOL INTO APPROPRIATE ANCHOR.



WITH ABOVE GROUND ANCHOR



WITH IN-GROUND FLUSH MOUNT

BAY MASTER M1 CENTER POST

STEP 3

GENTLY SEPARATE EACH RIB FROM CENTER POST APPROXIMATELY 4 TO 8 INCHES. IF RIB DOES NOT MOVE EASILY, DO NOT FORCE. INSPECT PRODUCT FOR ADDITIONAL PACKAGING.

